



Flexibler Raupenkran mit Effer 525

- Scanreco Funksteuerung mit Display
- Progress 2.0
- Dieselmotor Tier 5
- Stahdraupen gummiert
- Elektromotor 380V / 15KW mit Inverter
- Hubarbeitsbühne EN 280
- PSaG



Interessant für Sie?



**Beratung &
Konzept**

Bei uns sind Sie gut aufgehoben

Kompakt Kran C52

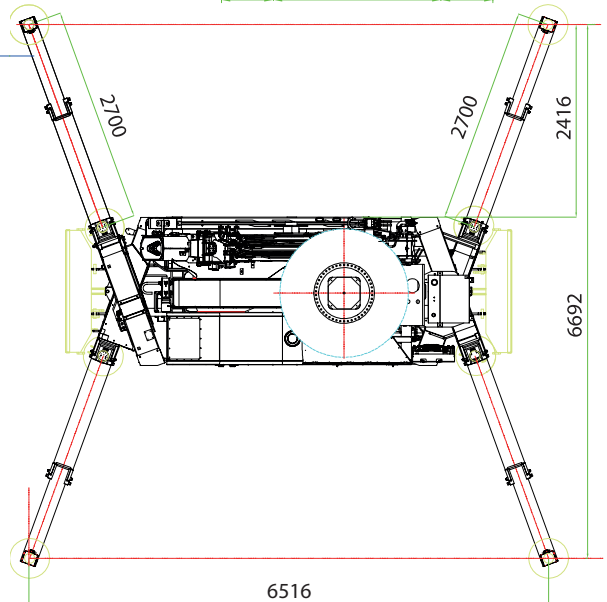
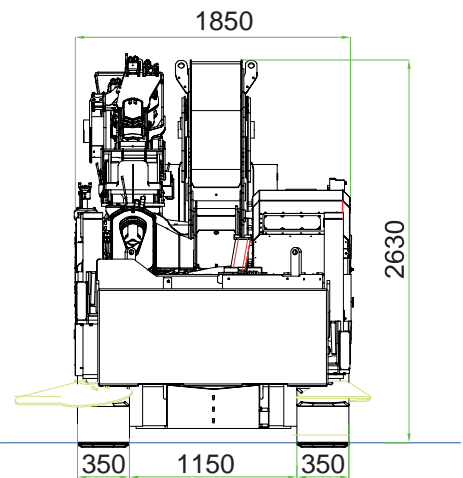
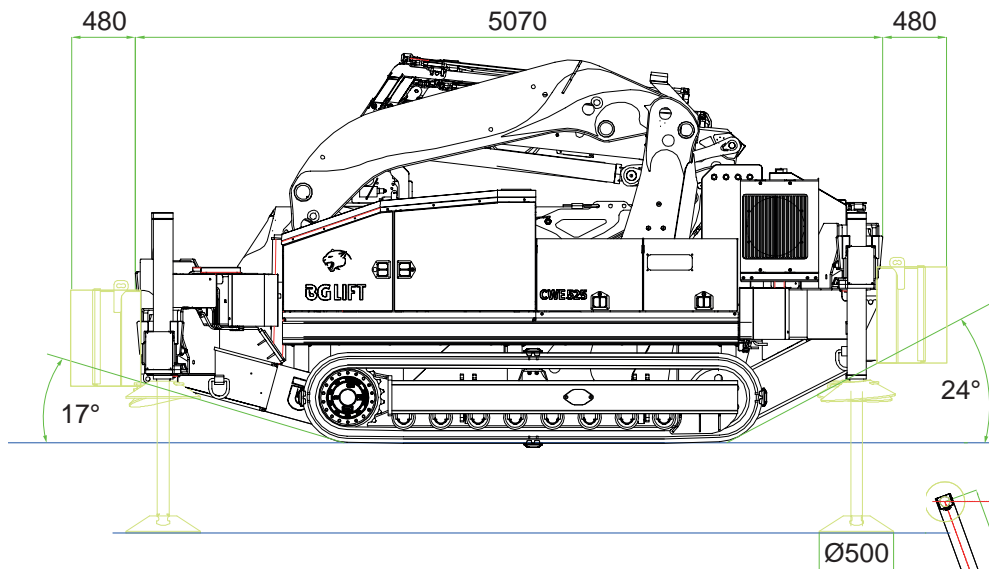
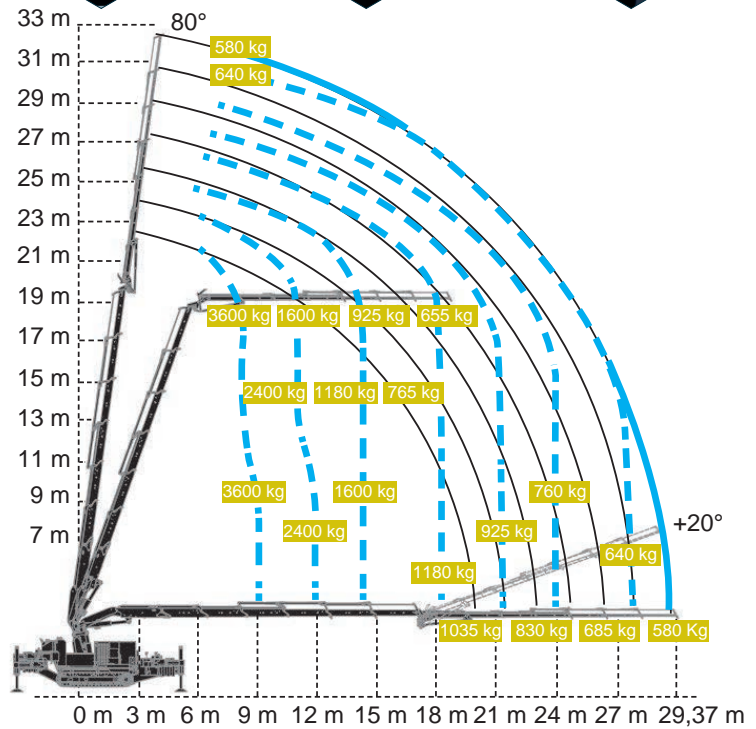
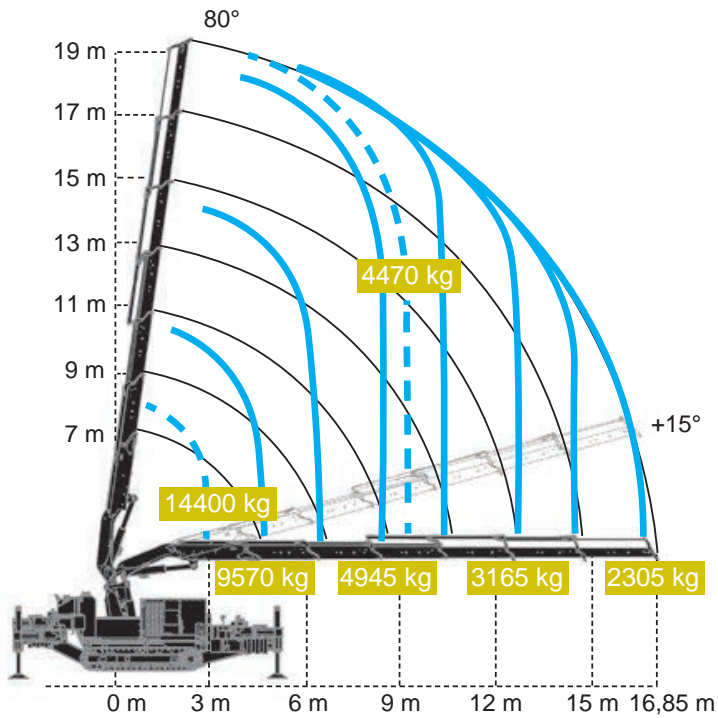
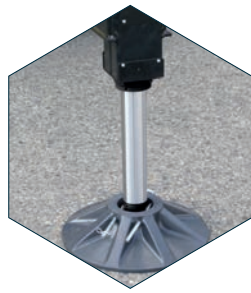

Technische Daten

Schwenkbereich	Endlos
Seilwinde	1'900 / 2'500 kg
Diesel Motor	Yanmar 55 Kw / 291 Nm
Fahrtgeschwindigkeit	1,2 / 2,2 km/h
Max. überwindbare Steigung	24°

Gewichte

Grundmaschine	14'200 kg
Jib	1'200 kg
Ballast	2 x 1'800 kg
Gewicht total	19'000 kg
Stahlstaukasten	2 x 160 kg